

Transjugular liver access and biopsy

An illustrated guide

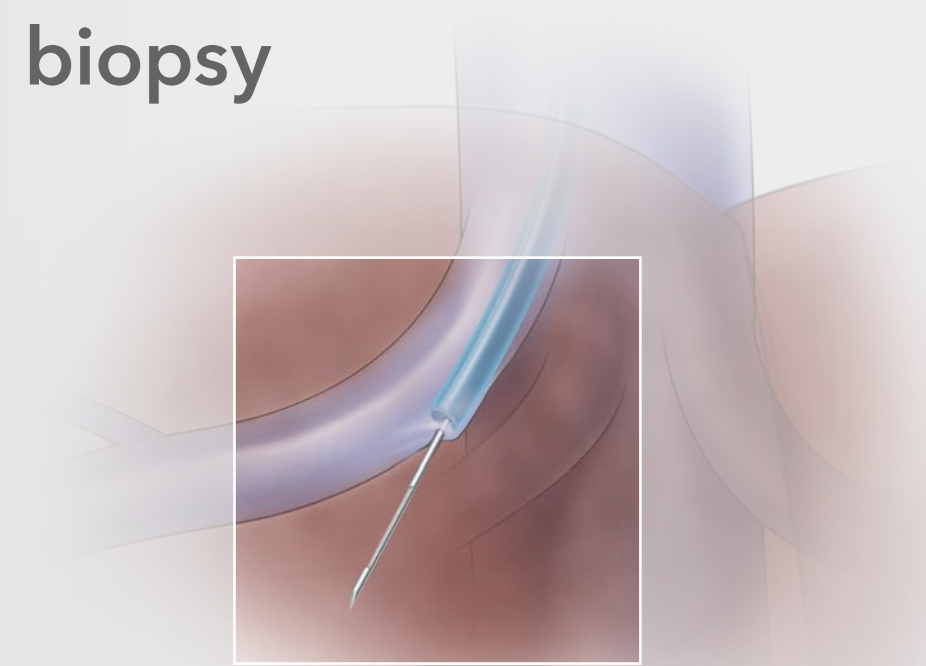

Illustrations by Lisa Clark

LABS

LIVER ACCESS AND BIOPSY SET

Support your procedures by using products that are specifically designed for transjugular liver access and biopsy.

The set includes a full complement of components for transjugular liver access and tissue biopsy.

- Indicated for adult and pediatric use.
- The transjugular approach provides an alternative to percutaneous biopsy for patients who have abnormal clotting or ascites.
- The catheter and cannula are precurved to facilitate hepatic vein access.
- The single-throw mechanical needle passes easily into tissue and provides optimal and reproducible tissue specimens.

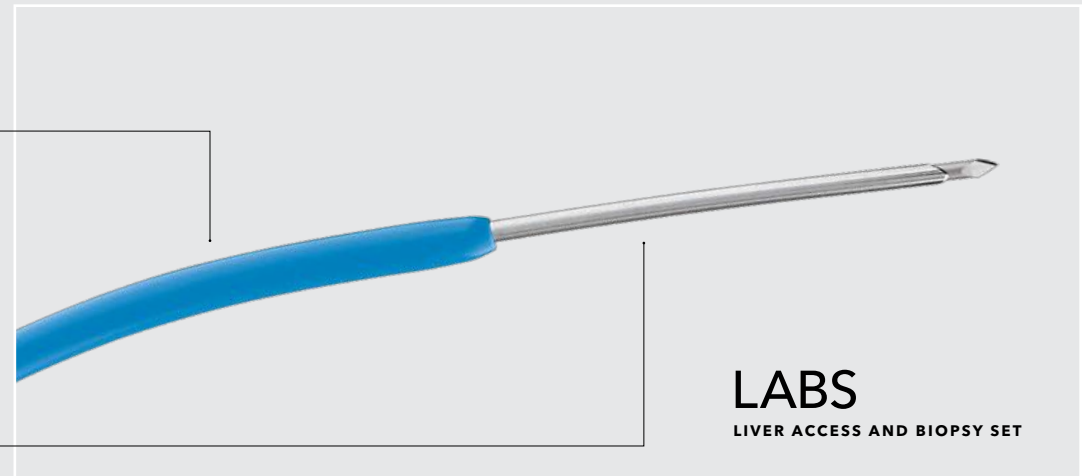

Order Number	Reference Part Number	Needle gage	Needle Length cm	Needle Throw Length mm	Sheath Fr
Liver Access and Biopsy Set					
G57485	LABS-100-J-01	18	60	20	7
G57487	LABS-200-J-01	19	60	20	7
Liver Access and Biopsy Needle					
G57482	RMT-14XT-50.5-LABS-100-01	18	60	20	7
G57483	RMT-14XT-50.5-LABS-200-01	19	60	20	7

Some products or part numbers may not be available in all markets. Contact your local Cook representative or Customer Service for details.

Transjugular liver access and biopsy

An illustrated guide

Caution: Federal (USA) law restricts the use of these devices to sale by or on the order of a physician. Refer to the Instructions for Use (IFU) for complete product information and full prescribing information including indications, contraindications, warnings, and precautions.

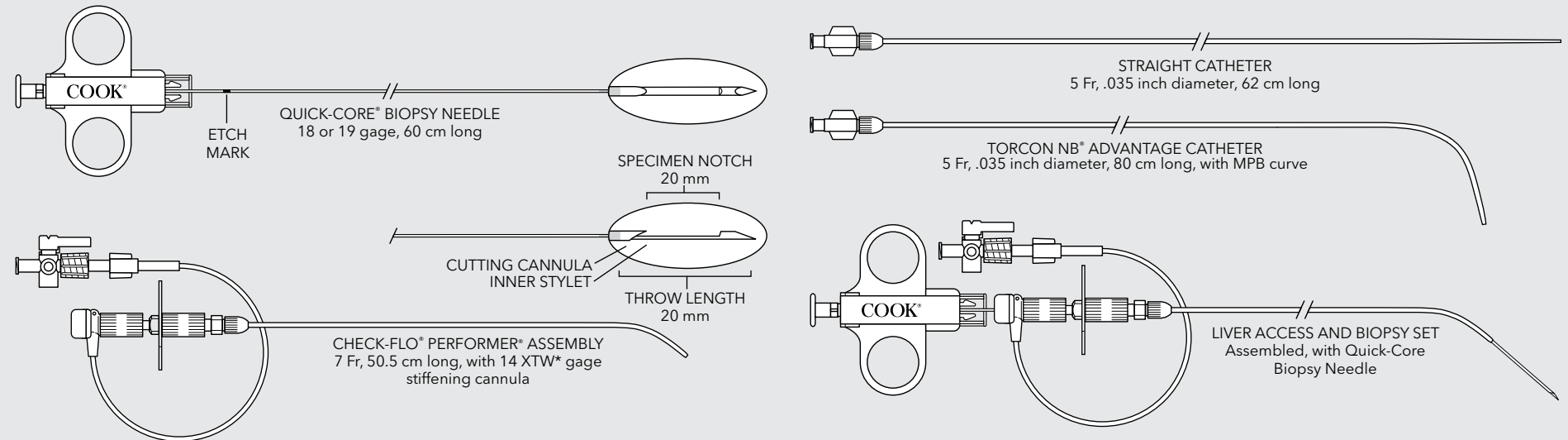

*Extra-thin wall

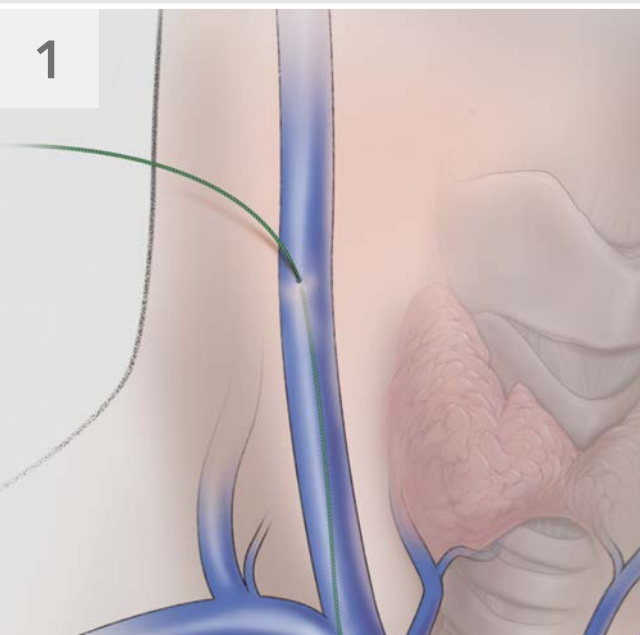

Warnings: Extreme care must be exercised during manipulation and withdrawal of the catheter in order to prevent pulling the catheter apart. Insertion through a synthetic vascular graft should be avoided whenever possible.

Use standard access techniques to introduce an appropriate .035 inch diameter wire guide into the inferior vena cava via the jugular vein.

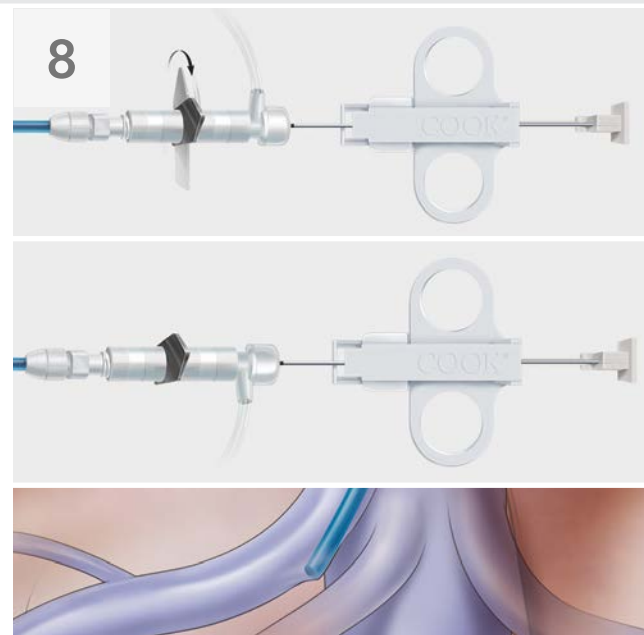

Using the directional arrow on the hub of the metal stiffening cannula, direct the Check-Flo Performer assembly and the Quick-Core Biopsy Needle in the desired direction for biopsy, and apply gentle forward pressure to "tent" the wall of the hepatic vein adjacent to the biopsy site.

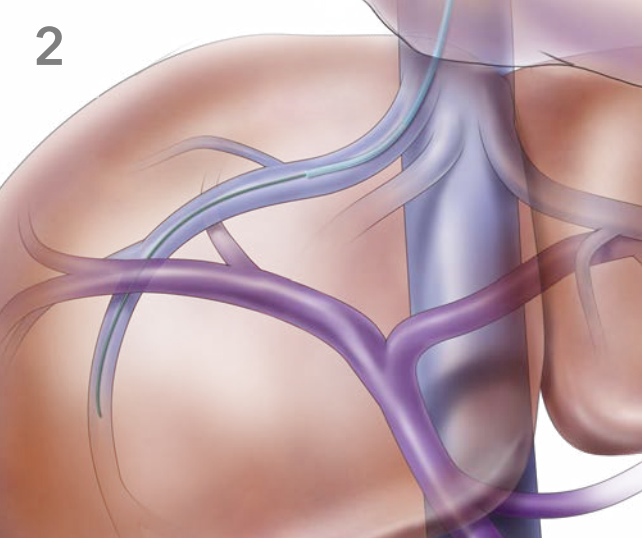

2

Using a selective catheter and a wire guide of your choice, catheterize the right hepatic vein (RHV) or an appropriate alternative hepatic vein branch.

Caution: To prevent cardiac arrhythmias, continuous cardiac monitoring is recommended while negotiating past the right atrium.

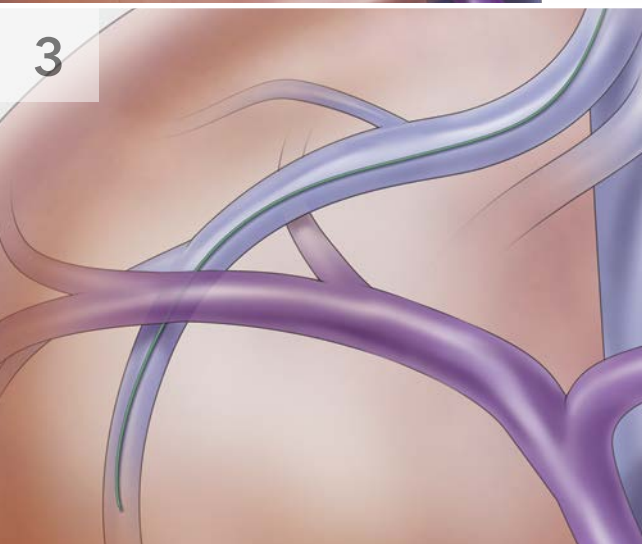

3

Leave the wire guide in a safe, distal position, and remove the selective catheter.

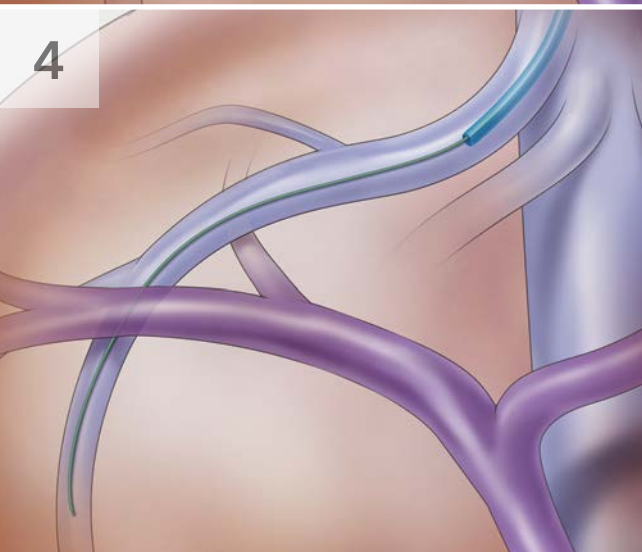

4

Introduce and advance the Check-Flo Performer assembly over the wire guide into the selected hepatic vein.

When introducing this assembly, the included straight catheter may be used to facilitate introduction.

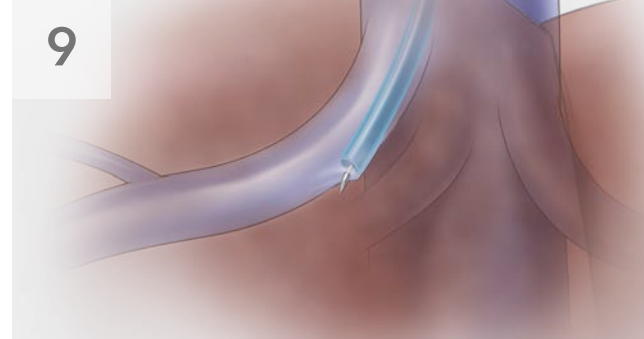

9

Advance the Quick-Core Biopsy Needle out of the tip of the Check-Flo Performer assembly and into the liver tissue. **Do not advance the stylet until the Quick-Core Biopsy Needle is in position.**

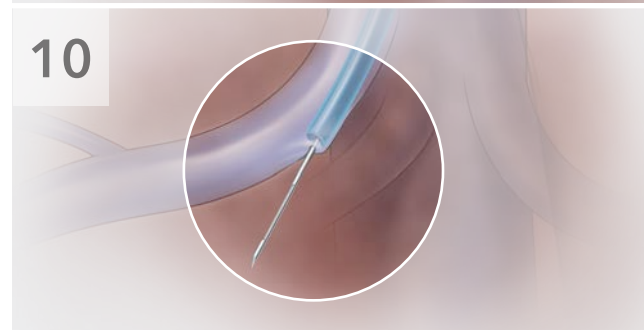

10

While you maintain the position of the Quick-Core Biopsy Needle, advance the stylet to expose the specimen notch within the area to be biopsied.



Fire the cutting cannula by fully depressing the plunger to capture the tissue within the specimen notch.

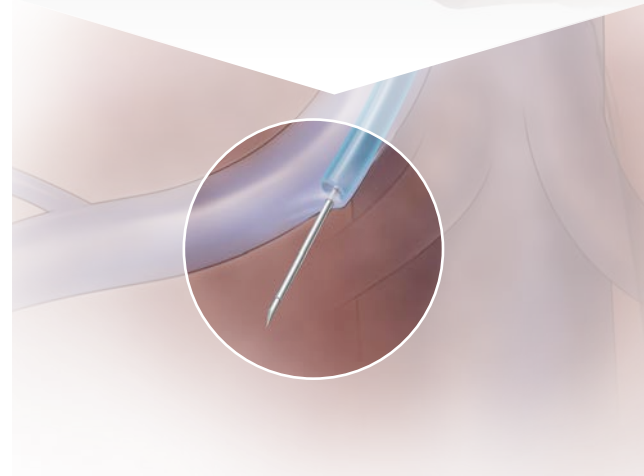

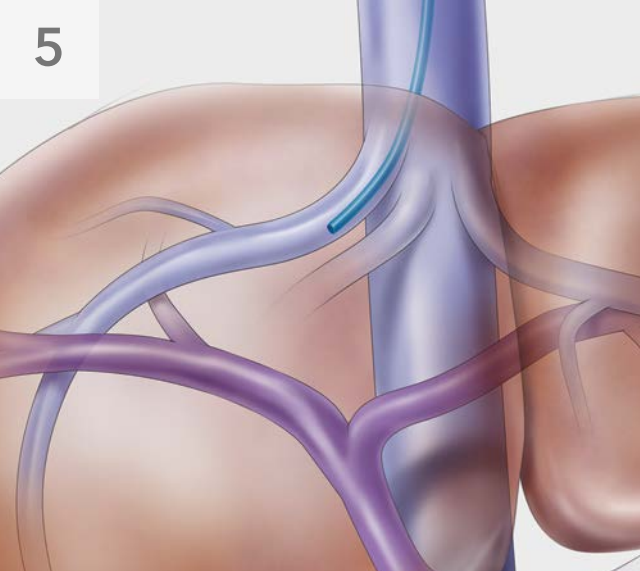

After the Check-Flo Performer assembly is positioned within the hepatic vein, remove the straight catheter and the wire guide.

Note: Take care to prevent damage to the straight catheter when removing the straight catheter through the metal stiffening cannula. Leaving a wire guide through the straight catheter during removal may aid in preventing damage to the straight catheter.



Prepare the Quick-Core Biopsy Needle by pulling back on the plunger until you feel a firm click, indicating that the needle spring is locked into the ready position. The specimen notch should now be completely covered by the cutting cannula.



With the stylet fully retracted, advance the Quick-Core Biopsy Needle through the Check-Flo Performer assembly until the etch mark on the proximal cannula is at the hub of the Check-Flo valve adapter. This will position the needle tip at the distal end of the access assembly.



Withdraw the Quick-Core Biopsy Needle from the biopsy area and take it completely out of the Check-Flo Performer assembly.



To remove the tissue specimen, pull back on the plunger until you feel a firm click. The click indicates that the cutting cannula is locked into position.



Push the stylet forward to expose the tissue specimen.

Note: Stop forward motion when you feel resistance in order to avoid engaging the Quick-Core Biopsy Needle firing mechanism again.



Remove the specimen from the notch.

Customer Service

EU Website: cookmedical.eu

EDI: cookmedical.eu/edi

Distributors: +353 61239240, ssc.distributors@cookmedical.com

Austria: +43 179567121, oe.orders@cookmedical.com

Belgium: +32 27001633, be.orders@cookmedical.com

Denmark: +45 38487607, da.orders@cookmedical.com

Finland: +358 972519996, fi.orders@cookmedical.com

France: +33 171230269, fr.orders@cookmedical.com

Germany: +49 6950072804, de.orders@cookmedical.com

Hungary: +36 17779199, hu.orders@cookmedical.com

Ireland: +353 61239252, ie.orders@cookmedical.com

Italy: +39 0269682853, it.orders@cookmedical.com

Netherlands: +31 202013367, nl.orders@cookmedical.com

Norway: +47 23162968, no.orders@cookmedical.com

Spain: +34 912702691, es.orders@cookmedical.com

Sweden: +46 858769468, se.orders@cookmedical.com

Switzerland - French: +41 448009609, fr.orders@cookmedical.com

Switzerland - Italian: +41 448009609, it.orders@cookmedical.com

Switzerland - German: +41 448009609, de.orders@cookmedical.com

United Kingdom: +44 2073654183, uk.orders@cookmedical.com

USA Website: cookmedical.com

EDI: cookmedical.com/edi.do

Americas:

Phone: +1 812.339.2235, 800.457.4500, Fax: 800.554.8335

E-mail: orders@cookmedical.com

Australia:

Phone: +61 734346000, 1800777222, Fax: +61 734346001, 1800077283

E-mail: cau.custserv@cookmedical.com



AI, ESC, IR, OHNS, PI, RH, SUR-85X11